

600  
PSI  
SP

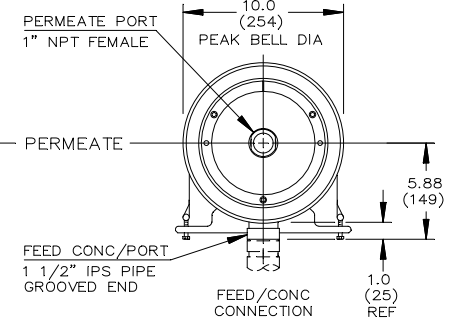

VIEW AT CENTER SUPPORT  
CENTER VESSEL ON 2 OR 3 SUPPORTS  
AT SPAN(S) "S": 3 SUPPORTS REQUIRED  
FOR LENGTHS -4 AND OVER

CAUTION—INCORRECT MANIFOLDING  
WILL CAUSE SEVERE LOCAL STRESS  
AROUND PORT AND MAY RESULT IN  
LEAKS AND PREMATURE FAILURE;  
TAKE EVERY PRECAUTION LISTED  
ON REVERSE, SEE INSTALLATION  
INSTRUCTIONS FOR FURTHER DETAILS

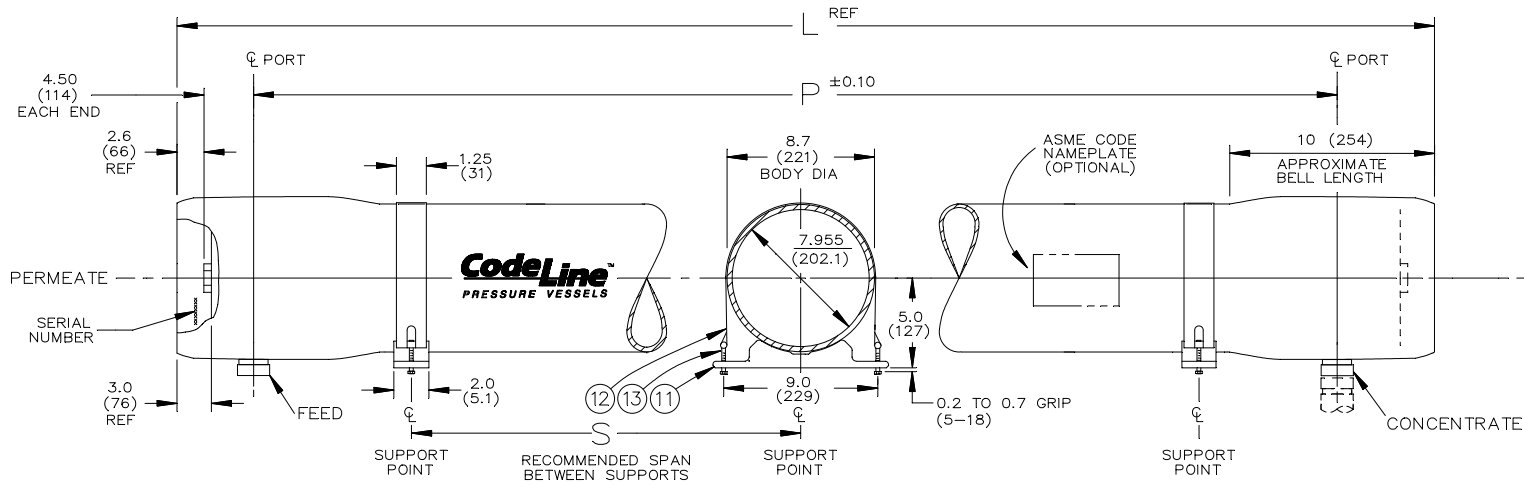
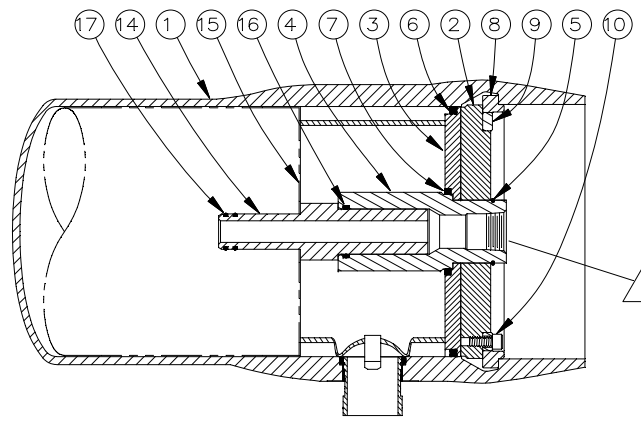

WARNING!  
INTERNAL PORT PRESSURE  
MUST NOT EXCEED 125 PSI

SECTION THROUGH END CLOSURE  
ITEM (15) DOWNSTREAM ONLY

ASME CODE NAMEPLATE (OPT.)  
CERTIFIED BY  
ADVANCED STRUCTURES, INC.  
d.b.a. CodeLine  
ESCONDIDO, CALIFORNIA U.S.A.  
MAX. W.P. 600 P.S.I. 120°F.  
MIN. OPER. TEMP. 20 °F.  
MFG. SER. \_\_\_\_\_  
YR. B.LT. \_\_\_\_\_

- NOTES
- SHELL EXTERIOR COATED WITH WHITE, HIGH GLOSS POLYURETHANE PAINT
  - DIMENSION IN INCHES (MM APPROX.)
  - NOT TO BE USED FOR CONSTRUCTION UNLESS CERTIFIED

Shell Length Code	L L.O.A. IN (MM)	P Port to Port IN (MM)	S Span IN (MM)	Empty Weight LB (KG)
1	59.0 (1499)	45.0 (1143)	28 X 1 (711)	80 (27)
2	99.0 (2515)	85.0 (2159)	56 X 1 (1422)	105 (48)
3	139.0 (3531)	125.0 (3175)	80 X 1 (2032)	135 (61)
4	179.0 (4547)	165.0 (4191)	64 X 2 (1626)	160 (73)
5	219.0 (5563)	205.0 (5207)	78 X 2 (1981)	190 (86)
6	259.0 (6579)	245.0 (6223)	92 X 2 (2337)	215 (98)
7	299.0 (7595)	285.0 (7239)	106 X 2 (2692)	245 (111)
7.5	319.0 (8103)	305.0 (7747)	114 X 2 (2896)	260 (118)
8	339.0 (8611)	325.0 (8255)	120 X 2 (3048)	270 (124)

**CodeLine**  
PRESSURE VESSELS  
by  
**CodeLine DIVISION**  
STRUCTURAL NORTH AMERICA  
Escondido, California U.S.A.

MODEL E8B/SP  
BRACKISH RO PRESSURE VESSEL  
SIDEWALL PORTING

Dwg. Ref.	Qty. Per Part	Part Name	Materials/Remarks
SHELL			
①	1	Shell	Filament wound epoxy/glass composite—Head locking grooves integrally wound in-place, with F/C side-ports.
HEAD			
②	2	50664 Bearing Plate	6061-T6 aluminum alloy—hard anodized
③	2	50667 Sealing Plate	PVC Thermoplastic
④	2	50670 Permeate Port	PVC Thermoplastic
⑤	2	45248 Port Retainer	304 Stainless Steel, Triarc type
⑥	2	45320 Head Seal	Ethylene Propylene, Quad Ring
⑦	2	45350 Perm Port Seal	Ethylene Propylene, square-cut
HEAD INTERLOCK			
⑧	6	50758 Locking Ring	Cast Aluminum—hard anodized
⑨	2	50676 Securing Ring	Reinforced Plastic - Yellow Color
⑩	6	45228 Securing Screws	316 Stainless Steel
VESSEL SUPPORT			
⑪	*3	45102 Saddle	Engineering Thermoplastic
⑫	*3	45042 Strap Assy	304 Stainless Steel - PVC cushion
⑬	4	46265 Strap Screw	18-8 Stainless Steel
ELEMENT INTERFACE			
⑭	2	As Required Adapter	Engineering Thermoplastic
⑮	1	50214 Thrust Ring Assy	Engineering Thermoplastic
⑯	2	45308 Adapter Seal	Ethylene Propylene - O-Ring
⑰	4	As Required PWT Seal	Ethylene Propylene - O-Ring
*2 each furnished with length code 1, 2 & 3			

ENGR AP 18MAR99	MODEL E8B/SP BRACKISH RO PRESSURE VESSEL SIDEWALL PORTING			
QLTY RAP 18MAR99	ECO 89639	SHEET 1 OF 1	SIZE B	NUMBER 507015
MRKT SH 18MAR99				REV H

**RATING:**

DESIGN PRESSURE..... 600 PSI at 120°F  
 (4.1 MPa at 49°C)  
 MIN. OPERATING TEMP..... 20°F  
 (-7°C)  
 FACTORY TEST PRESSURE..... 900 PSI  
 (6.2 MPa)  
 BURST PRESSURE..... 3600 PSI  
 (24.8 MPa)

**INTENDED USE**

The Model E8B/SP Fiberglass RO Pressure Vessel is designed for continuous, long-term use as a housing for reverse osmosis membrane elements to desalt typical brackish waters at pressures up to 600 psi. Any make of—eight inch nominal diameter spiral—wound element is easily accommodated; the appropriate interfacing hardware for the element specified is furnished with the vessel.

The model E8B/SP is designed in accordance with the engineering standards of the Boiler and Pressure Vessel Code of the American Society of Mechanical Engineers (ASME Code). At small additional cost, vessels can be inspected during construction by an ASME Authorized Inspector and ASME Code stamped.

The Model E8B/SP must be installed, operated and maintained in accordance with the precautions listed and good industrial practice to assure safe operation over a long service life.

The high performance reinforced plastic shell must be allowed to expand under pressure; undue restraint at support points or piping connections can cause leaks to develop in the shell. This side—ported vessel requires special precautions in mounting and connection to piping so that the vessel will not be subjected to excessive stress due to bending moments acting at the side openings in the fiberglass shell.

The end closures, incorporating close—fitting, interlock—ing metal components, must be kept dry and free of corrosion; deterioration can lead to catastrophic mechanical failure of the heads.

CodeLine Division, Structural North America will assist the purchaser in determining the suitability of this standard vessel for their specific operating conditions. The final determination however, including evaluation of the standard materials of construction for compatibility with the specific corrosive environment, shall be the responsibility of the purchaser. Alternate materials with enhanced corrosion resistance are available on special order.

Specifications subject to change without notice.

**PRECAUTIONS**

- DO... read, understand and follow all instructions; failure to take every precaution will void warranty and may result in vessel failure
- DO... mount shell centered on horizontal members spaced at recommended span(s) "S" using compliant mounting hardware furnished; tighten hold down straps just snug
- DO... align and center side ports with the manifold header; correct causes of misalignment in a row of vessels connected to the same header
- DO... use flexible type grooved—end pipe couplings, Victaulic® Style 77 or equal, at sideports; allow full .125 inch gap between port and piping, and position piping to maximize flexibility of connection
- DO... provide flexibility in, and support for piping manifold so that vessel can grow in length under pressure without undue restraint; provide additional flexible joints in large pipes leading to manifold header
- DO... provide overpressure protection for vessel set at not more than 105% of design pressure
- DO... inspect end closures regularly; replace components that have deteriorated and correct causes of corrosion
- DO NOT...work on any component until first verifying that pressure is relieved from vessel
- DO NOT...make rigid piping connections to ports or clamp vessel in any way that restricts growth of fiberglass shell under pressure; ▲DIA = 0.015 in. (0.4mm) and ▲L = 0.25 in. (6mm) for a length code —8 vessel
- DO NOT...hang piping manifolds from ports or use vessel in any way to support other components
- DO NOT...tighten Permeate Port connection more than one turn past hand tight
- DO NOT...operate vessel without connecting both Permeate Ports internally to a complete set of elements or otherwise plug ports internally so that external piping connection is not subjected to feed pressure
- DO NOT...install Spacer on downstream end of vessel
- DO NOT...operate vessel without Thrust Ring installed downstream
- DO NOT...pressurize vessel until double checking to verify that all three segments of Locking Ring Set are in place, and that the Securing Ring is fully seated and secured by all three Securing Screws
- DO NOT...operate vessel at pressures and temperatures in excess of its rating
- DO NOT...operate vessel with permeate pressure in excess of 125 psi at 120°F (0.9 MPa at 49°C)
- DO NOT...tolerate leaks or allow end closures to be routinely wetted in any way

**ORDERING**

Please specify the following:

- VESSEL MODEL NUMBER built from table of options below
- MEMBRANE ELEMENT MODEL NUMBER
- SPECIFIC CONCERNS regarding INTENDED USE and requests for SPECIAL MATERIALS of CONSTRUCTION

A vessel model number specifies a complete assembly less element interface components. The required interface components are furnished with the vessel but are specified separately.

Membrane elements and between—element connectors (interconnectors) are furnished by membrane element manufacturer.

