



**RATING:**

DESIGN PRESSURE.....1200 PSIG  
(8.27 MPa)  
 MAX. OPERATING TEMP.....150°F  
(66°C)  
 MIN. OPERATING TEMP.....20°F  
(-7°C)  
 FACTORY TEST PRESSURE.....CE / ASME  
 1800PSIG/1320 PSIG  
 (12.41MPa)/ (9.10 MPa)  
 QUALIFICATION PRESSURE .....7200 PSI  
 (49.64 MPa)

**INTENDED USE:**

The CodeLine 80U120 Fiberglass RO Pressure Vessel is designed for continuous, long term use as housing for reverse osmosis membrane elements to desalt typical sea waters at pressures up to 1200 psi. Any make of eight-inch nominal diameter spiral-wound element is easily accommodated; the appropriate interfacing hardware for the element specified is furnished with the vessel.

The CodeLine 80U120 is designed in accordance with the engineering standards of the Boiler and Pressure Vessel Code of the American Society of Mechanical Engineers (ASME) as per Section X. At small additional cost vessels can be inspected during construction by an ASME Authorized Inspector and ASME Code stamped.

The CodeLine 80U120 must be installed, operated and maintained in accordance with the listed precautions and good industrial practice to assure safe operation over a long service life.

The high performance Filament wound FRP shell must be allowed to expand under pressure; undue restraint at support points or piping connections can cause leaks to develop in the shell. This side-ported vessel requires special precautions in mounting and connection to piping so that the vessel will not be subjected to excessive stress due to bending moments acting at the side openings in the fiberglass shell. The end closure, incorporating close fitting, interlocking metal components, must be kept dry and free of corrosion; deterioration can lead to catastrophic mechanical failure of the head.

Pentair will assist the purchaser in determining the suitability of this standard vessel for their specific operating conditions. The final determination however, including evaluation of the standard material of construction for compatibility with the specific corrosive environment, shall be the responsibility of the purchaser. Alternate materials with enhanced corrosion resistance are available on special order.

Specifications are subject to change without notice.

**PRECAUTIONS:**

- DO...read, understand and follow all instructions; failure to take every precaution will void warranty and may result in vessel failure
- DO...mount the shell on horizontal members at span “S” using compliant vessel supports furnished; Shim saddles if required. Tighten hold down straps just snug
- DO...align and center side ports with the manifold header. Correct, causes of misalignment in a row of vessels connected to the same header
- DO...use flexible type IPS grooved-end pipe couplings, at side ports; allow full, 0.125 inch gap between port and piping, and position piping to maximize flexibility of connection.
- DO...provide flexibility in, and support for piping manifolds so that vessel can grow in length under pressure without undue restraint; provide additional flexible joints in large pipes leading to manifold header.
- DO...provide overpressure protection for vessel set at not more than 105% of design pressure
- DO...inspect end closures regularly; replace components that have deteriorated and correct causes of corrosion
- DO... Lubricate seals sparingly, using nonpetroleum Based lubricants, i.e. Parker Super O-lube®, Glycerin or suitable silicone based lubricants.
- DO NOT...work on any component until first verifying that pressure is relieved from vessel
- DO NOT...make rigid piping connections to ports or clamp vessel in any way that resists growth of fiberglass shell under pressure;  
 \*\*\*ΔDIA = 0.015 in. (0.4mm) and  
 \*\*\*ΔL = 0.2 in. (6mm) for a length code –8 vessel
- DO NOT... hang piping manifolds from ports or use vessel in any way to support other components
- DO NOT...tighten Permeate Port connection more than one turn past hand tight
- DO NOT... operate vessel without connecting both Permeate Ports internally to complete set of elements or otherwise plug ports internally so that external piping connection is not subjected to feed pressure
- DO NOT...install Spacer on downstream end of vessel
- DO NOT...operate vessel without Thrust Cone installed downstream
- DO NOT...pressurize vessel until double-checking to verify that the Locking Ring is in place and fully seated.
- DO NOT...operate vessel at pressure and temperature in excess of its rating.
- DO NOT...operate vessel with permeate pressure in excess of 125 psi at 150°F (0.86 Mpa at 66°C).
- DO NOT...tolerate leaks or allow end closures to be routinely wetted in any way
- DO NOT...operate outside the pH range 3-11.

For complete information on proper use of the vessel Please refer to the 80U Series USER’S GUIDE 94182.

**ORDERING:**

Using the chart below, please check the features you require

**VESSEL LENGTH CODE – please check one**

MODEL 80U120  -1  -2  -3  -4  -5  -6  -7  -8

**MEMBRANE BRAND AND MODEL**

Please supply adapters for the following membrane brand and specific model  
 Brand \_\_\_\_\_ Model \_\_\_\_\_

**CERTIFICATION REQUIRED**

- Hydro testing at 1.1 times the design pressure.
  - ASME Stamped and National Board Registered.
  - In compliance with the ASME Sec X, but not Code Stamped
- Hydro testing at 1.5 times the design pressure.
  - CE Marked Standard.

ADAPTER KITS	
UP STREAM	DOWN STREAM

**PERMEATE PORT SELECTION**

Serial Number End

Size of the Permeate Port  1”  1.25”  1.5”  
 Type of Connection  FNPT  MNPT  BSPTM  BSPTF  IPS GROOVED  
 Material of Construction  Noryl  SS316L  Zeron 100

Non Serial Number End

Size of the Permeate Port  1”  1.25”  1.5”  
 Type of Connection  FNPT  MNPT  BSPTM  BSPTF  IPS GROOVED  
 Material of Construction  PET/Noryl  SS316L  Zeron 100

Note:

- Standard offering is 1.0” FNPT in Noryl.
- 1.25” & 1.5” BSPTF, 1.25” & 1.5” FNPT connections cannot be offered

**STRAP ASSEMBLY**

Standard SS304  Optional SS316  Optional SS316L

**FEED/CONCENTRATE PORT SELECTION**

Material of Construction  STD Super Duplex SS (CD3MWCuN)  
 Optional - CE3MN\* (Cannot be offered for ASME stamped vessels)  
 Configuration  Standard –1 I 5 I  
 Optional –Multi port: (Refer PAGE 3 for 3”-4” for Multi ports selection). Ports not available in 90° configurations.

Serial number end

Opposite end

**BEARING PLATE MATERIAL**

Standard – 6061 T6 Aluminium  
 Optional – Stainless Steel 316L

PORT SIZE CODE	
G	3” GROOVED END
I	4” GROOVED END

Note: Refer page-3 for optional Part numbers.

BEARING PLATE PART NUMBERS		
PERMEATE PORT SIZE	ALUMINIUM	SSF316L ###
1.0"/1.25"	96158	96475
1.5"	96343	97370

SEALING PLATE PART NUMBERS	
Standard used for Aluminium BP	96159
Optional used for SS316L BP	97404

PERM PORT RETAINER RING & PORT NUT PART NUMBERS		
1.0" / 1.25"	Standard Port nut	45066
1.5"	Port Retainer Ring	45247

STRAP ASSEMBLY PART NUMBERS		
SS304	SS316	SS316L
45042	46926 <sup>+</sup>	94371 <sup>+</sup>

F/C PORT & SEAL PART NUMBER			
SIZE	***CD3MWCuN	**CE3MN	SEAL
4"	96648	98813	96265
3"	96663	98812	96119

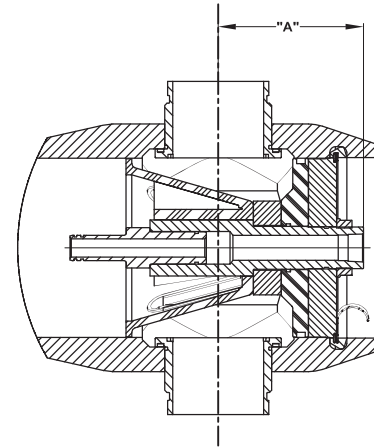

SECTION THROUGH END CLOSURE

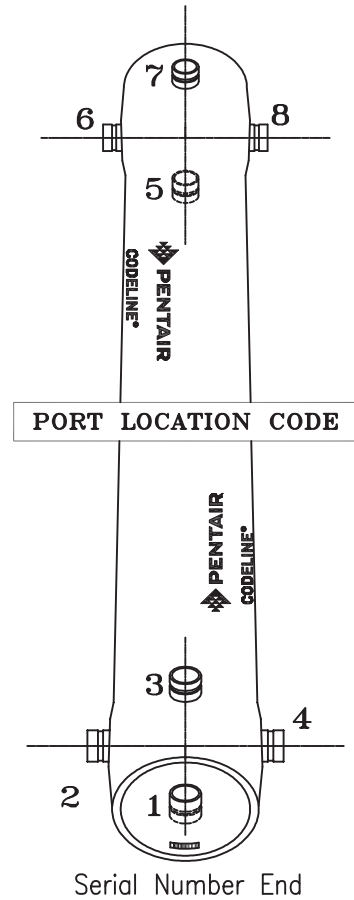

CODELINE BODY LABELS ARE PLACED AT 90° TO SERIAL NUMBER END AND AT 270° ON THE OPPOSITE SIDE END

PERMEATE PORT PART NUMBERS & PERMPORT TO F/C PORT OFFSET DISTANCE											
SIZE	MATERIAL	FNPT		MNPT		BSPTF		BSPTM		IPS GROOVED	
		PART NUMBER	DIM "A"	PART NUMBER	DIM "A"	PART NUMBER	DIM "A"	PART NUMBER	DIM "A"	PART NUMBER	DIM "A"
1.0"	PET/NORYL	96263	6.8	97411	7.8	97414	6.8	97417	7.8	97420	8.1
	SS316L ##	97410	6.8	97412	7.8	97415	6.8	97418	7.8	97421	8.1
	#ZERON 100	97296	6.8	97413	7.8	97416	6.8	97419	7.8	97422	8.1
1.25"	PET/NORYL	NA	NA	97467	7.8	NA	NA	97425	7.8	97428	8.1
	SS316L ##	NA	NA	97423	7.8	NA	NA	97426	7.8	97429	8.1
	#ZERON 100	NA	NA	97424	7.8	NA	NA	97427	7.8	97430	8.1
1.5"	PET/NORYL	NA	NA	97431	7.4	NA	NA	97434	7.4	97437	8.0
	SS316L ##	NA	NA	97432	7.4	NA	NA	97435	7.4	97438	8.0
	#ZERON 100	NA	NA	97433	7.4	NA	NA	97436	7.4	97439	8.0

NOTES

- DIMENSION IN INCHES (MM APPROX.)
- \*\* GRADE CE3MN AS PER SA-995 (UNS J93404)
- \*\*\* GRADE CD3MWCuN AS PER SA-995 (UNS J93380)
- # GRADE ZERON 100 AS PER SA-479 (UNS S32760)
- ## GRADE SS-316L AS PER SA-479
- ### GRADE SS-F316L AS PER SA-182
- + OPTIONAL STRAP ASSEMBLY WITH SS-316 & 316L SHALL BE SUPPLIED AS PER METRIC STANDARDS

DRAWN	YPS	MODEL - 80U120			
	04MAY17	MEMBRANE HOUSING			
CHECKED	KPS	DATE	DWG. NO.	REV.	
	04MAY17	26DEC17	99188	B	
APPROVED	MKS	ECN	SCALE	SIZE	SHEET
	04MAY17	4624	NONE	A3	3 OF 3

**PENTAIR**  
CODELINE®